

**MARINE EVACUATION SYSTEM (MES)  
ORIL 151 VENTURI WITH CENTRAL BOWSING LINES  
ASSOCIATED WITH SMALL INFLATABLE SLIDE (SIS) &  
EVACUATION SLIDE SYSTEM (ESS) - VERTICAL**

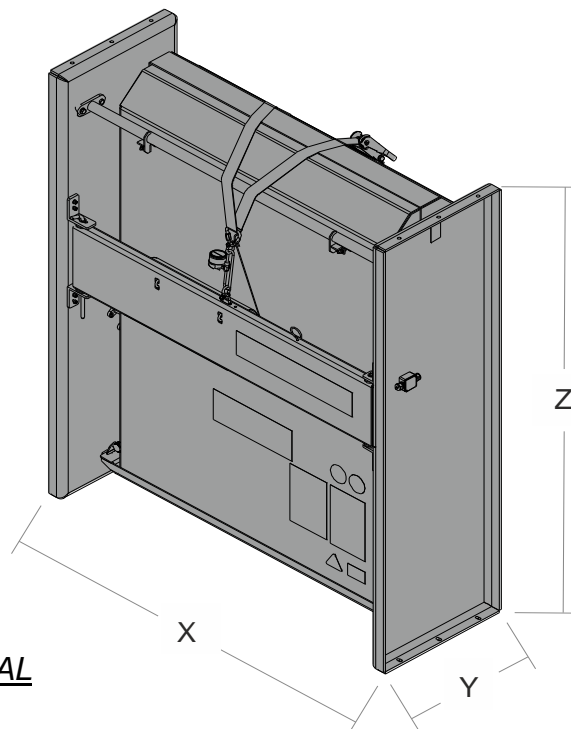
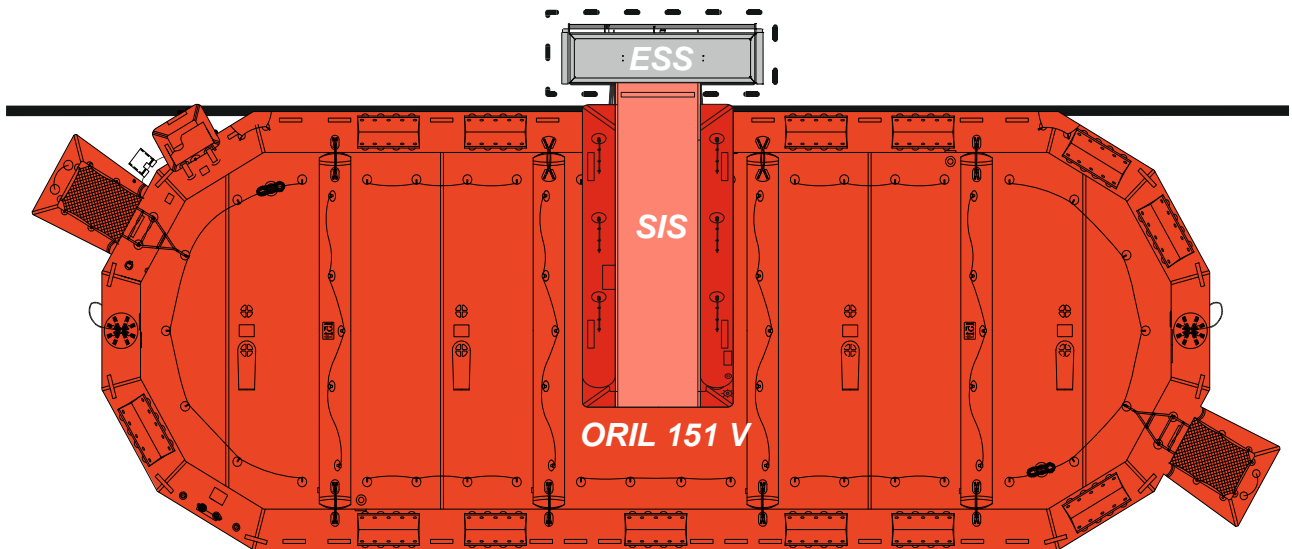

ESS 1000 VERTICAL

<b>Maximum height stowage</b>	<b>1,70 m</b>		
<b>ESS 1000 VERTICAL</b>			
Complete System Dimensions	X: 1700mm	Y: 635mm	Z: 2000mm
	X: 5' 6,93"	Y: 2' 1"	Z: 6' 6,75"
System Net Weight	546 kg / 1204 pounds		

<b>Maximum height stowage</b>	<b>2,20 m</b>		
<b>ESS 1000 VERTICAL</b>			
Complete System Dimensions	X: 1700mm	Y: 635mm	Z: 2000mm
	X: 5' 6,93"	Y: 2' 1"	Z: 6' 6,75"
System Net Weight	550 kg / 1213 pounds		

<b>Maximum height stowage</b>	<b>2,70 m</b>		
<b>ESS 1000 VERTICAL</b>			
Complete System Dimensions	X: 1700mm	Y: 635mm	Z: 2000mm
	X: 5' 6,93"	Y: 2' 1"	Z: 6' 6,75"
System Net Weight	558 kg / 1231 pounds		

<b>Maximum height stowage</b>	<b>3,20 m</b>		
<b>ESS 1000 VERTICAL</b>			
Complete System Dimensions	X: 1700mm	Y: 635mm	Z: 2000mm
	X: 5' 6,93"	Y: 2' 1"	Z: 6' 6,75"
System Net Weight	560 kg / 1235 pounds		

<b>Maximum height stowage</b>	<b>3,80 m</b>		
<b>ESS 1000 VERTICAL</b>			
Complete System Dimensions	X: 1700mm	Y: 635mm	Z: 2000mm
	X: 5' 6,93"	Y: 2' 1"	Z: 6' 6,75"
System Net Weight	568 kg / 1253 pounds		

<b>Approvals:</b>	<b>EC</b>
-------------------	-----------

ESS MES SIS CBL VERT 151 V 02082017 KLT	Issue: 1	Date: 02/08/2017
---	----------	------------------

Dimensions and weight +/- 5%  
 SURVITEC SAS reserves the right to change specification without notice.  
 For installation, add minimum +10mm for clearance to dimensions of the container.